

6	SOCKET CASING	31562-0000	1	
5	IP2X PHASE PIN CAL.18	12797-5000		
	IP2X PHASE PIN CAL.16	12948-5000		
	IP2X PHASE PIN CAL.14	12476-5000		
4	AUXILIARY FEMALE CONTACT CAL.6	11136-5000	2	19
3	EARTH FEMALE CONTACT CAL.14	11132-5000	1	
2	3+E IP2X MALE PIN CONTACT CARRIER 240	31175-1050	1	
	3+E IP2X MALE PIN CONTACT CARRIER	31175-0000	1	
1	CABLE TERMINAL TO CRIMP OR SOLDER 240 ²	13275-0110		3
	CABLE TERMINAL TO CRIMP OR SOLDER 185 ²	13237-0110		35
	CABLE TERMINAL TO CRIMP OR SOLDER 150 ²	11993-0110		35
	CABLE TERMINAL TO CRIMP OR SOLDER 120 ²	11284-0110		32
	CABLE TERMINAL TO CRIMP OR SOLDER 95 ²	11146-0110		32
Ind	Description	Reference	Cont.	Strip. A

ASSEMBLY INSTRUCTIONS

- 1- PREPARE THE CABLES AS SCHEME BELOW.
- 2- CRIMP OR SOLDER CABLE TERMINALS (1) ON PHASE CABLES AND EARTH CABLE [TOOL Nr 5 AND 6].
- 3- UNSCREW FLANGE (6.1) [TOOL Nr 3] THEN SLIDE IT OVER THE CABLE WITH SHOULDER SIDE TO THE FRONT. SLIDE SEAL (6.2) TOO.
- 4- ENGAGE EARTH CONTACT (3) IN THE HOLE OF EARTH EAR IN THE MIDDLE OF SOCKET CASING (6).
- 5- PLACE CABLE TERMINAL (1) OF EARTH CABLE AT THE BACKSIDE OF EARTH CONTACT (3), SCREW CONTACT, WHEN CABLE TERMINAL HEXAGON TOUCH EARTH EAR OF SOCKET CASING (6), PUSH IT INSIDE OF EARTH EAR TO BLOCK IT, THEN TIGHTEN CONTACT (3) (TORQUE 20Nm) [TOOL Nr 1 AND 2].
- 6- REMOVE SCREWS OF CONTACTS (4) [TOOL Nr 4], INTRODUCE PILOT CABLES IN BACKSIDE OF CONTACTS AND PUT SCREW IN CONTACTS THEN TIGHTEN [TOOL Nr 4].
- 7- INTRODUCE EACH CABLE TERMINAL (1) AT THE BACKSIDE OF INSERT (2), HEXAGON OF CABLE TERMINAL MUST CORRESPOND WITH HEXAGON INSIDE OF THE IP2X PHASE MALE PIN, THEN SCREW CONTACTS (5) IN THE FRONT OF IP2X PHASE MALE PIN (TORQUE 20Nm) [TOOL Nr 1 AND 2].
- 8- INTRODUCE INSERT (2) IN THE SOCKET (6) AND FIX FLANGE (6.1) [TOOL Nr 3].
- 9- PLACE SEAL (6.2) AT THE BACKSIDE OF SOCKET (6).

LIST OF TOOLS *

- 1- TORQUE WRENCH FACOM REF. J.306A50
- 2- SOCKETS FACOM : 3/8" Nr17 REF: J.17LA
3/8" Nr19 REF: J.19LA
3/8" Nr21 REF: J.21
- 3- ANGLED SOCKET WRENCH OR OPEN END WRENCH 13mm
- 4- FLAT SCREWDRIVER Nr 3
- 5- CRIMPING TOOL KLAUKE HK 120 U
- 6- KLAUKE CRIMPING JAW: 95° REF: HNFF 13/95
120° REF: HNFF 13/120
150° REF: HNFF 13/150
185° REF: HNFF 13/185
240 REF: HNFF 13/240

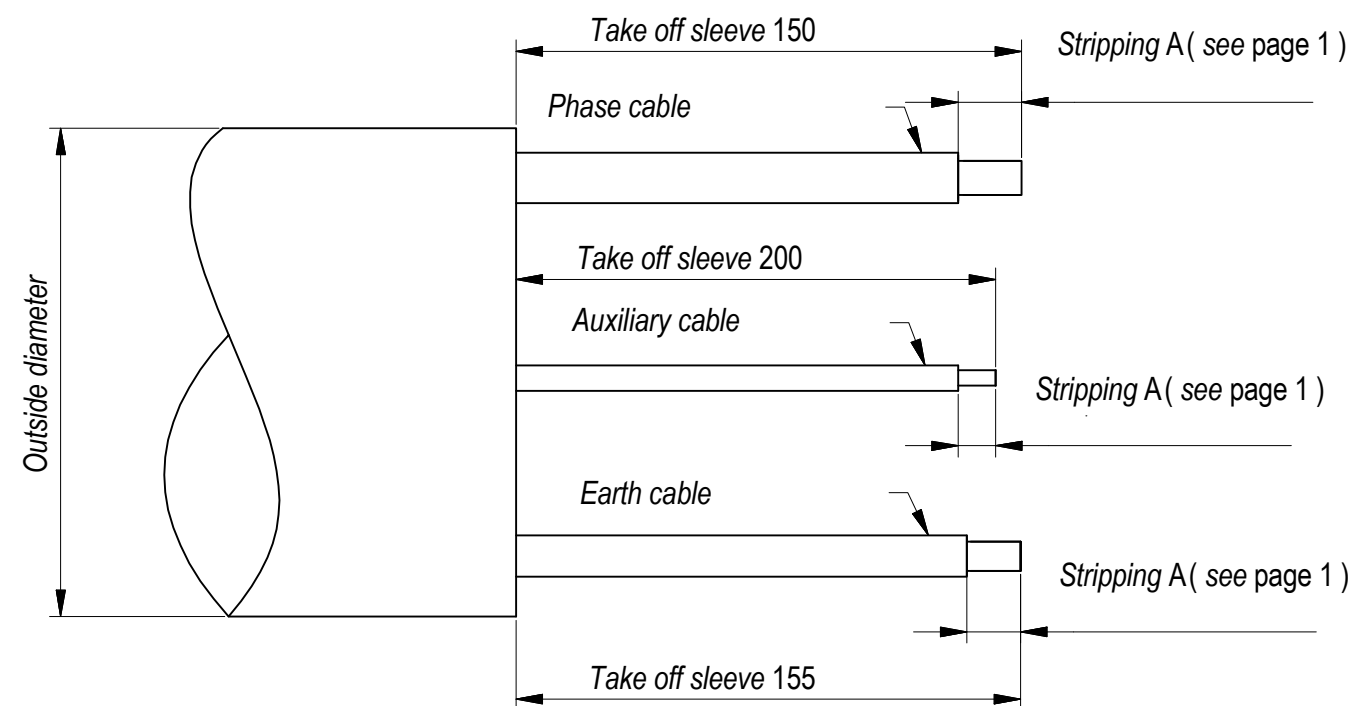

* TOOL REFERENCES ARE ONLY RECOMMENDED AND GIVEN AS EXAMPLES. TOOLS ARE NOT PROVIDED OR IMPOSED BY SCAME.